

General

These accessories are a range of devices for completing a pneumatic circuit. These valves, with their special functions, are inserted between two valves, between a valve and a cylinder, or following a cylinder.

One of the particular characteristic of these accessories is that they are automatically actuated without the need for external commands. Usually, operation and idle are controlled by the presence or absence of pressure as, for example, in the case of quick exhaust valves which pilots itself as a selector, changing the flow direction as the signal goes off and on.

On the other hand, other components are inert. That is, they do not have any internal variable function which is sensitive to pressure. Among these components are silencers, manifolds and flow regulators.

There are also the flow regulators, which like electronic components, can be defined as variable resistances. They are fundamental in regulating the flow rate, provide precise timings and regulate the cylinders' speed.

The selector valves, with "AND" and "OR" functions, are logic functions components which often are an essential element. Furthermore, they are built to allow high flow rate which cannot be obtained by classic pneumatic logic.

The block valves lock the cylinder in a position, avoiding unexpected depressurization of the cylinder's chamber due to lack of compressed air at the inlet port. Practically, it is a piloted unidirectional valve that blocks the exhaust port when there is no air in the pilot circuit.

Finally the economizer valves are in fact a pressure reducer valves installed between valve and cylinder for reducing the air consumption. For example this is applicable on the cylinder return stroke without penalizing the exhaust as happens with FRL pressure regulator.

Construction characteristics

We have not listed all different materials used for the construction of these components because the list would be too the long. We use corrosion proof material, brass or anodized aluminium and the most appropriate specific mixture for seals. If more information is required please contact our technical department.

Use and maintenance

In operation pay attention to the minimum and maximum criteria for temperature and pressure, and ensure good quality compressed air. In a dirty environment, protect the exhaust ports. In this case, maintenance is minimal and is necessary only if the air is particularly dirty. The components most subject to damage by the accumulation of dirt are flow regulators with fine regulation and silencers. As for regulators, follow the normal procedure for disassembling, washing with non-chemical cleaning agents and remounting. The silencers need only to be rinsed in petrol or solvent and blown dry with compressed air.

The number of requests for spare seals for flow regulators and shuttle valves are statistically irrelevant. More often, it is necessary to replace the lining of the quick exhaust because of the wear it undergoes due to the particular conditions of operating.

ATTENTION: for lubrication use class H hydraulic oils, for example Castrol MAGNA GC 32.

Miniature flow control valve M5 - Ø3 tube

Ordering code	6.01.305.F
FUNCTION	
1.2 = Unidirectional	
2.1 = Unidirectional	
1.1 = Bidirectional	

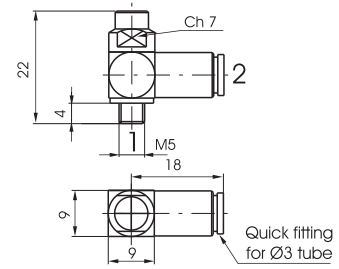

Weight gr. 14

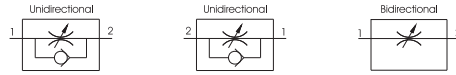

Operational characteristic	Fluid	Max working pressure	Operating Temperature		Orifice size
	Filtered air	10 bar	Min. -5°C	Max. +70°C	mm. 1,5

Miniature flow control valve M5 - Ø3 tube, with adjustment knob

Ordering code	6.01.305.FP
FUNCTION	
1.2 = Unidirectional	
2.1 = Unidirectional	
1.1 = Bidirectional	

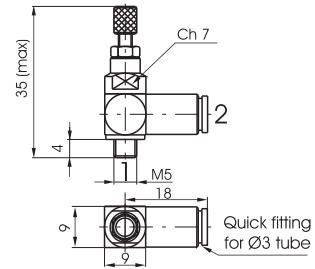

Weight gr. 16

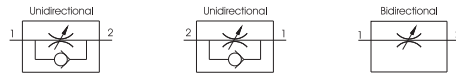

Operational characteristic	Fluid	Max working pressure	Operating Temperature		Orifice size
	Filtered air	10 bar	Min. -5°C	Max. +70°C	mm. 1,5

Miniature flow control valve M5 - Ø3,17 tube

Ordering code	6.01.315.F
FUNCTION	
1.2 = Unidirectional	
2.1 = Unidirectional	
1.1 = Bidirectional	

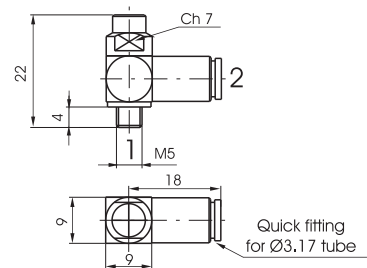

Weight gr. 14

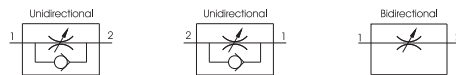

Operational characteristic	Fluid	Max working pressure	Operating Temperature		Orifice size
	Filtered air	10 bar	Min. -5°C	Max. +70°C	mm. 1,5

Miniature flow control valve M5 - Ø3,17 tube, with adjustment knob

Ordering code	6.01.315.FP
FUNCTION	
1.2 = Unidirectional	
2.1 = Unidirectional	
1.1 = Bidirectional	

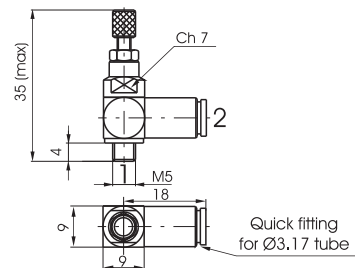

Weight gr. 16

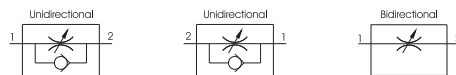

Operational characteristic	Fluid	Max working pressure	Operating Temperature		Orifice size
	Filtered air	10 bar	Min. -5°C	Max. +70°C	mm. 1,5

Miniature flow control valve M5 - Ø4 tube

Ordering code	
6.01.45.F	
FUNCTION	
1.2 = Unidirectional	
2.1 = Unidirectional	
1.1 = Bidirectional	

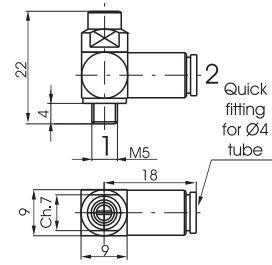

Weight gr. 14

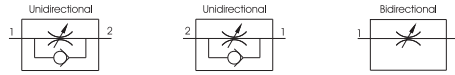

Operational characteristic	Fluid	Max working pressure	Operating Temperature		Orifice size
	Filtered air	10 bar	Min. -5°C	Max. +70°C	mm. 1,5

Miniature flow control valve M5 - Ø4 tube, with adjustment knob

Ordering code	
6.01.45.FP	
FUNCTION	
1.2 = Unidirectional	
2.1 = Unidirectional	
1.1 = Bidirectional	

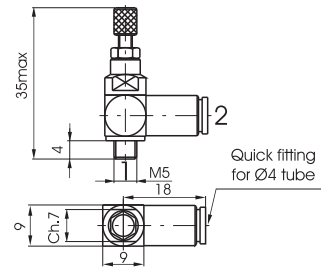

Weight gr. 16



Operational characteristic	Fluid	Max working pressure	Operating Temperature		Orifice size
	Filtered air	10 bar	Min. -5°C	Max. +70°C	mm. 1,5

Flow control valve M5 - in line ports

Ordering code	
6.01.F	
FUNCTION	
05 = Unidirectional	
05/2 = Bidirectional	

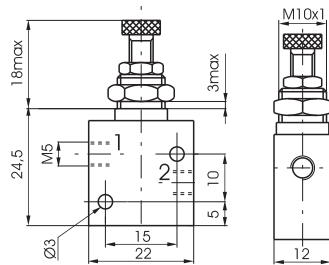

Weight gr. 48



Operational characteristic	Fluid	Max working pressure	Operating Temperature		Orifice size
	Filtered air	10 bar	Min. -5°C	Max. +70°C	mm. 2

Flow control valve M5 - port at 90°

Ordering code	
6.01.05.F	
FUNCTION	
90 = Unidirectional	
90/2 = Bidirectional	

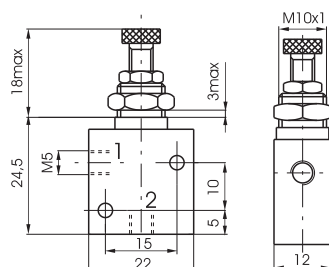

Weight gr. 48

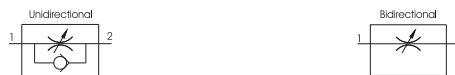

Operational characteristic	Fluid	Max working pressure	Operating Temperature		Orifice size
	Filtered air	10 bar	Min. -5°C	Max. +70°C	mm. 2

Flow control valve M5 - with a through bolt

Ordering code
6.01.05.F
FUNCTION
F 180 = Unidirectional
180/2 = Bidirectional

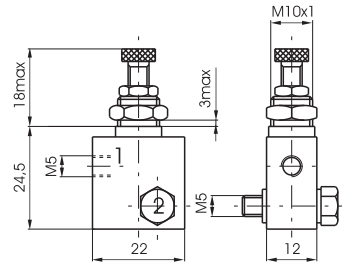

Weight gr. 52

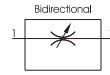
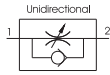

Operational characteristic	Fluid	Max working pressure	Operating Temperature		Orifice size
	Filtered air	10 bar	Min. -5°C	Max. +70°C	mm. 2

Flow control valve G1/8" - ultrasensitive

Ordering code
6.01.18/F
FUNCTION
F 4 = Unidirectional
5 = Bidirectional

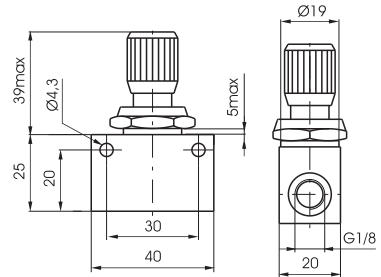

Weight gr. 100

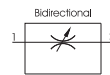

Operational characteristic	Fluid	Max working pressure	Operating Temperature		Orifice size
	Filtered air	10 bar	Min. -5°C	Max. +70°C	mm. 3

Flow control valve G1/8" - ultrasensitive with lock nut

Ordering code
6.01.18/F
FUNCTION
F 6 = Unidirectional
7 = Bidirectional

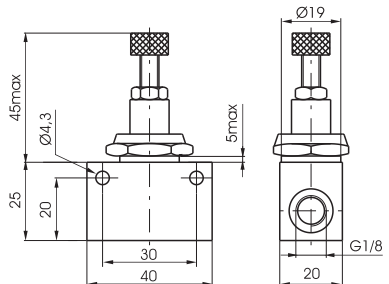

Weight gr. 105

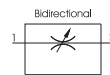
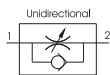

Operational characteristic	Fluid	Max working pressure	Operating Temperature		Orifice size
	Filtered air	10 bar	Min. -5°C	Max. +70°C	mm. 3

Flow control valve G1/8"

Ordering code
6.01.F
FUNCTION
F 18N = Unidirectional
18NE = Unidir. economic vers.
18/1N = Bidirectional
18/1NE = Bidir. economic vers.

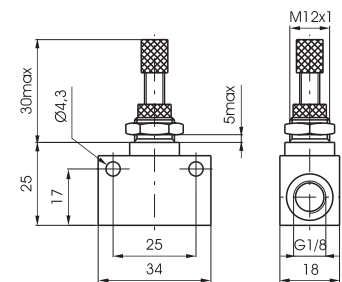

Weight gr. 50

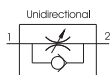

Operational characteristic	Fluid	Max working pressure	Operating Temperature		Orifice size
	Filtered air	10 bar	Min. -5°C	Max. +70°C	mm. 4

1

Flow control valve G1/4" - compact type - unidirectional

Ordering code
6.01.14/1

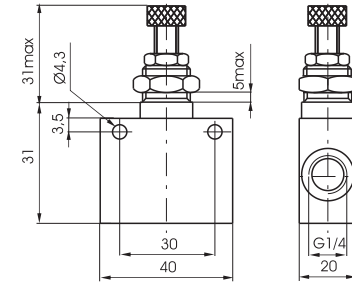

Weight gr. 100



Operational characteristic	Fluid	Max working pressure	Operating Temperature		Orifice size
	Filtered air	10 bar	Min. -5°C	Max. +70°C	mm. 5,5

Flow control valve G1/4"

Ordering code
6.01.F
FUNCTION
F 14N = Unidirectional
14/1N = Bidirectional

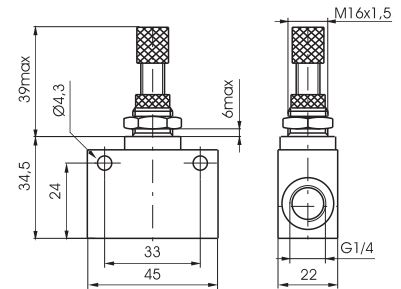

Weight gr. 105

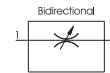
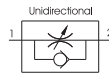

Operational characteristic	Fluid	Max working pressure	Operating Temperature		Orifice size
	Filtered air	10 bar	Min. -5°C	Max. +70°C	mm. 7

Flow control valve G1/2"

Ordering code
6.01.F
FUNCTION
F 12N = Unidirectional
12/1N = Bidirectional

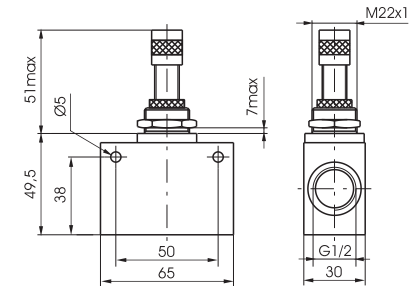

Weight gr. 505

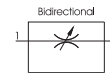

Operational characteristic	Fluid	Max working pressure	Operating Temperature		Orifice size
	Filtered air	10 bar	Min. -5°C	Max. +70°C	mm. 12

Flow control valve G3/4" - unidirectional

Ordering code
6.01.34

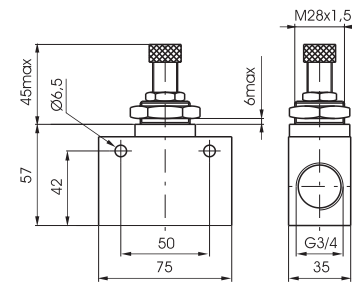

Weight gr. 500



Operational characteristic	Fluid	Max working pressure	Operating Temperature		Orifice size
	Filtered air	10 bar	Min. -5°C	Max. +70°C	mm. 12

Quick exhaust valve - M5 - G1/8" - G1/4" - G1/2"

Ordering code
6.02.1
CONNECTION
05 = M5
18 = G 1/8"
14 = G 1/4"
12 = G 1/2"

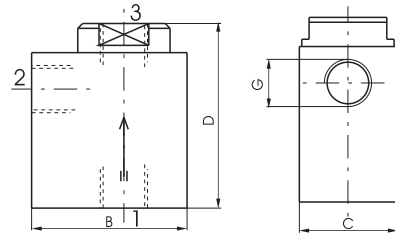

G	M5	1/8"	1/4"	1/2"
B	22	32	35	52
C	12	20	25	37
D	28	38	50	62
Weight gr.	50	62	112	310

Flow rate NI/min at 6 bar with $\Delta p = 1$	from 1 to 2	120	480	960	3300
Flow rate NI/min at 6 bar on free exhaust	from 2 to 3	220	1100	1930	6500

Weight "see table"

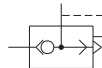

Operational characteristic	Fluid	Max working pressure	Operating Temperature	
	Filtered air	10 bar	Min. -5°C	Max. +70°C

Quick exhaust valve in line - M5 - M7 - G1/8"

Ordering code
6.02.1.C.L
CONNECTION (IN)
M5 = M5
03 = tube Ø3
04 = tube Ø4
06 = tube Ø6
CONNECTION (OUT)
M5 = M5
M7 = M7
18 = G1/8"
04 = tube Ø4
06 = tube Ø6

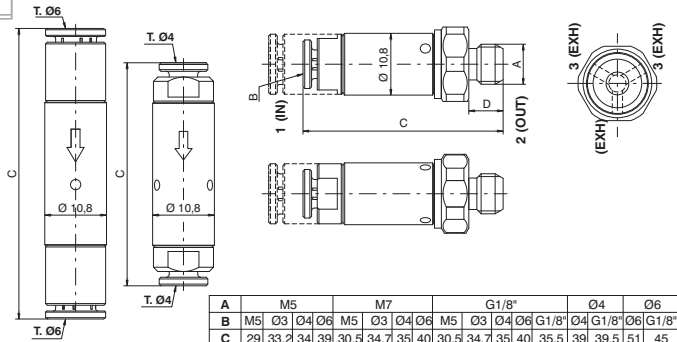

A	M5	M7	G1/8"		Ø4	Ø6
B	M5 Ø3 Ø4 Ø6	M5 Ø3 Ø4 Ø6	M5 Ø3 Ø4 Ø6	G1/8" Ø4 G1/8" Ø6 G1/8"	Ø4 G1/8" Ø6 G1/8"	Ø6 G1/8"
C	29 33 2 34 39	30,5 34,7 35 40	30,5 34,7 35 40	35,5 39 39,5 51 45		
D	4,5		6	- 5,5 - 5,5		
Weight (gr.)	17		18		17	20 18

Flow rate NI/min at 6 bar with $\Delta p = 1$ (from 1 to 2)	90	110	90	110
Flow rate NI/min at 6 bar on free exhaust (from 2 to 3)	240	350	240	350

Weight "see table"

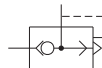

Operational characteristic	Fluid	Max working pressure	Operating Temperature	
	Filtered air	10 bar	Min. -5°C	Max. +70°C

Exhaust flow control - M5 - G1/8" - G1/4" - G1/2"

Ordering code
6.03.1
CONNECTION
05 = M5
18 = G 1/8"
14 = G 1/4"
12 = G 1/2"

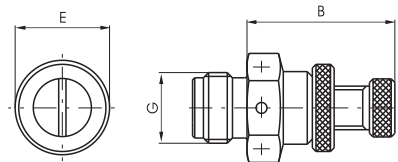

G	M5	1/8"	1/4"	1/2"
B	21	18	22	39
E	9	13	16	25
Weight gr.	10	18	32	155

Weight "see table"



Operational characteristic	Fluid	Max working pressure	Operating Temperature	
	Filtered air	10 bar	Min. -5°C	Max. +70°C

Shuttle valve "OR" - M5 - G1/8" - G1/4"

Ordering code

6.04.1

CONNECTION

- 05 = M5
- 18 = G 1/8"
- 14 = G 1/4"

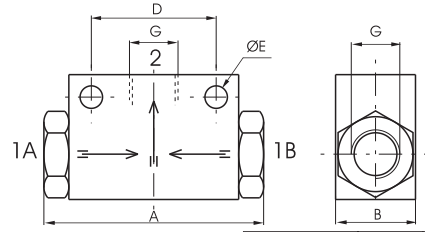

G	M5	1/8"	1/4"
A	27	44	62
B	12	16	22
D	15	25	35
E	3,5	4,5	5,5
Weight gr.	33	50	110

Flow rate at 6 bar with $\Delta p = 1$ NI/min. 110 700 2200

Weight "see table"

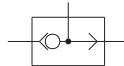

Operational characteristic	Fluid	Max working pressure	Operating Temperature	
	Filtered air	10 bar	Min. -5°C	Max. +70°C

Shuttle valve "OR" - T=4

Ordering code

6.04.04

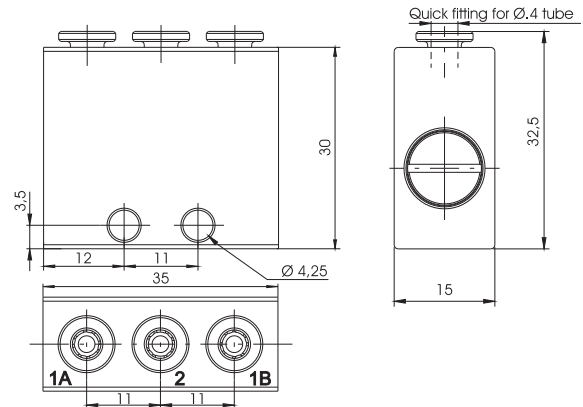

Weight gr. 50

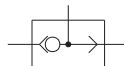

Operational characteristic	Fluid	Max working pressure	Operating Temperature		Flow rate 6 bar at $\Delta p = 1$	Orifice size	Connections
	Filtered and lubricated air	10 bar	Min. -5°C	Max. +70°C	105 NI/min	mm. 2,5	Fitting T=4

Shuttle valve "AND" - M5 - G1/8"

Ordering code

6.04.1/1

CONNECTION

- 05 = M5
- 18 = G 1/8"

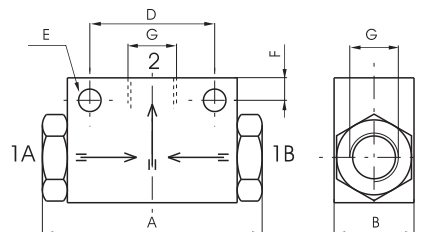

G	M5	1/8"
A	36	44
B	12	16
D	20	25
E	3,2	4,5
F	3,5	4,5
Weight gr.	30	50

Flow rate at 6 bar with $\Delta p = 1$ NI/min. 100 480

Weight "see table"

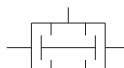

Operational characteristic	Fluid	Max working pressure	Operating Temperature	
	Filtered air	10 bar	Min. -5°C	Max. +70°C

Shuttle valve "AND" - T=4

Ordering code
6.04.04/1

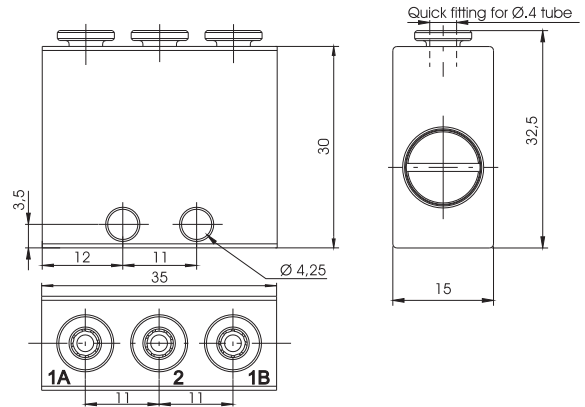

Weight gr. 50

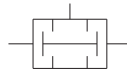

Operational characteristic	Fluid	Max working pressure	Operating Temperature	Flow rate 6 bar at $\Delta p=1$	Orifice size	Connections
	Filtered air	10 bar	Min. -5°C Max. +70°C	105 Nl/min	mm. 2,5	Fitting T=4

Silencers steel wool - G1/8" - G1/4" - G3/8" - G1/2"

Ordering code
6.05.1
CONNECTION
18 = G 1/8"
14 = G 1/4"
38 = G 3/8"
12 = G 1/2"

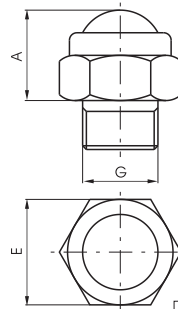

G	1/8"	1/4"	3/8"	1/2"
A	12	13	15	17
E	14	17	22	27
Weight gr.	8	16	32	44

Weight "see table"



Operational characteristic	Fluid	Max working pressure	Operating Temperature
	Filtered air	10 bar	Min. -5°C Max. +70°C

Silencers brass M5 - G1/8" - G1/4" - G3/8" - G1/2" - G3/4" - G1"

Ordering code
6.06.1
CONNECTION
05 = M5
18 = G 1/8"
14 = G 1/4"
38 = G 3/8"
12 = G 1/2"
34 = G 3/4"
01 = G 1"

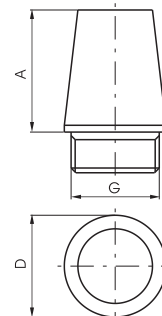

G	M5	1/8"	1/4"	3/8"	1/2"	3/4"	1"
A	17	15	18	28	32	40	50
D	8	12	15	19	23	29	38
Weight gr.	4	8	15	35	50	92	182

Weight "see table"



Operational characteristic	Fluid	Max working pressure	Operating Temperature
	Filtered air	10 bar	Min. -5°C Max. +70°C

G 1/8" compact check valves

Ordering code
6.07.18.Ⓔ
SEALS
Ⓔ R = NBR
VR = FPM

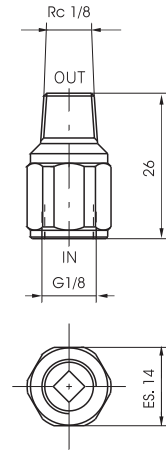

Weight gr. 50

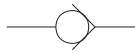

Operational characteristic	Fluid	Max working pressure	Operating Temperature		Flow rate 6 bar at Δp=1
	Filtered air	Min. 2.5 bar Max.	Min. -5°C	Max. +70°C	100 NI/min

Check valves M5 - G/18" - G1/4" - G3/8" - G1/2"

Ordering code
6.07.Ⓙ
POPPET
05 = NBR - M5
18 = NBR - G 1/8"
14 = NBR - G 1/4"
38 = NBR - G 3/8"
12 = NBR - G 1/2"
18V = FPM - G 1/8"
14V = FPM - G 1/4"
38V = FPM - G 3/8"
12V = FPM - G 1/2"

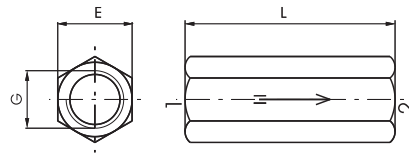

G	M5	1/8"	1/4"	3/8"	1/2"
E	10	14	17	21	25
L	21	37	48	50	60
Weight gr.	14	35	60	85	136

Flow rate at 6 bar with Δp = 1 NI/min. 160 650 1150 2600 3500

Weight "see table"



Operational characteristic	Fluid	Max working pressure	Operating Temperature	
	Filtered and lubricated air	10 bar	Min. -5°C	Max. +70°C (+150°C)

Manifold 4 ports M5 - G1/8" - G1/4" - G3/8" - G1/2"

Ordering code
6.08.ⓐ/4
CONNECTION
ⓐ 05 = M5
18 = G 1/8"
14 = G 1/4"
38 = G 3/8"
12 = G 1/2"

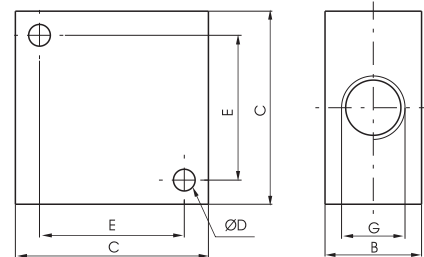

G	M5	1/8"	1/4"	3/8"	1/2"
B	10	16	20	20	30
C	20	32	40	40	50
D	3,3	4,5	4,5	5,5	6,5
E	14	22	30	30	38
Weight gr.	28	38	68	54	135

Weight "see table"

Operational characteristic	Fluid	Max working pressure	Operating Temperature	
	Filtered air	20 bar	Min. -5°C	Max. +70°C

Manifold 10 ports M5 - G1/8" - G1/4" - G3/8" - G1/2"

Ordering code	6.08.0/8
CONNECTION	05 = M5
18 = G 1/8"	
14 = G 1/4"	
38 = G 3/8"	
12 = G 1/2"	

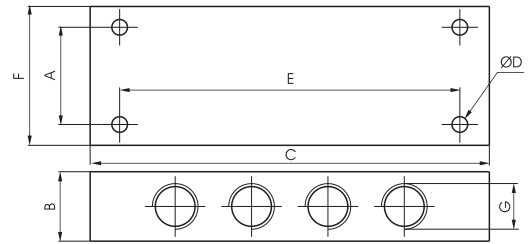

G	M5	1/8"	1/4"	3/8"	1/2"
A	16	20	28	28	36
B	12	18	20	20	30
C	60	90	115	130	170
D	3,3	4,5	4,5	5,5	5,5
E	50	75	98	112	150
F	22	32	40	40	50
Weight gr.	92	110	185	165	460

Weight *see table"

Operational characteristic	Fluid	Max working pressure	Operating Temperature	
	Filtered air	20 bar	Min. -5°C	Max. +70°C

Block valve G1/4"

Ordering code	6.09.14.F
FUNCTION	UN = Unidirectional
	BN = Bidirectional

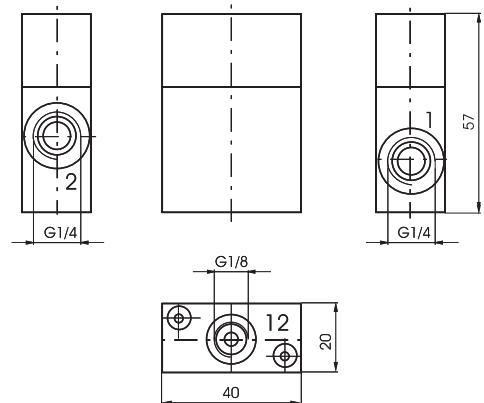

Weight gr. 122

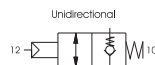

Operational characteristic	Fluid	Max working pressure	Min. piloting pressure	Operating Temperature		Flow rate at 6 bar with Δp=1	Orifice size
	Filtered and lubricated air	10 bar	4 bar	Min. -5°C	Max. +70°C	700 NI/min	mm. 7

Block valve G1/2"

Ordering code	6.09.12.F
FUNCTION	UN = Unidirectional
	BN = Bidirectional

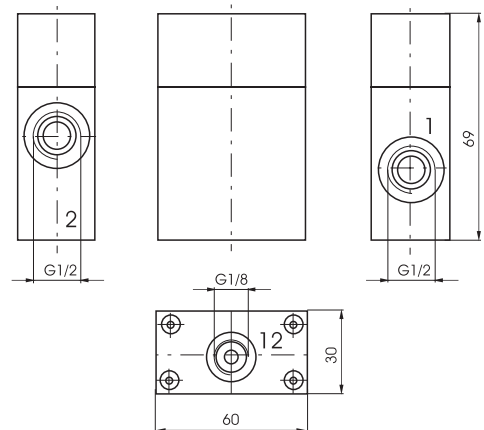

Weight gr. 305

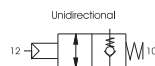

Operational characteristic	Fluid	Max working pressure	Min. piloting pressure	Operating Temperature		Flow rate at 6 bar with Δp=1	Orifice size
	Filtered and lubricated air	10 bar	4 bar	Min. -5°C	Max. +70°C	2000 NI/min	mm. 12

Economizer G1/8" - G1/4"

Ordering code

6.11.Ⓢ

CONNECTION

- 18 = G 1/8"
- 14 = G 1/4"

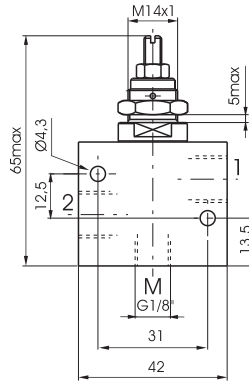

FLOW RATE CURVES
FROM 1 TO 2

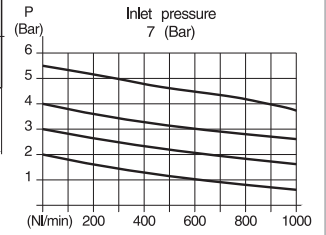

Weight gr. 85



Operational characteristic	Fluid	Max working pressure	Pressure range	Operating Temperature		Flow rate from port 2 to 1 at 6 bar with Δp=1	Orifice size
	Filtered and lubricated air	10 bar	0 - 5,5 bar	Min. -5°C	Max. +70°C	860 NI/min	mm. 6

Gang mounting manifold for valves and solenoid valves G 1/8"

Ordering code

6.10.18.18/N

* N. OF POSITIONS

- 2 = N. 2 positions
- 3 = N. 3 positions
- 4 = N. 4 positions
- 5 = N. 5 positions
- 6 = N. 6 positions
- 7 = N. 7 positions
- 8 = N. 8 positions
- 9 = N. 9 positions
- 10 = N. 10 positions

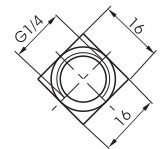
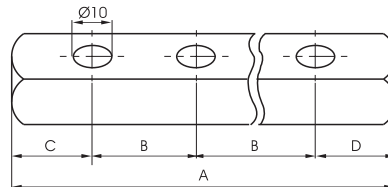

	* N. OF POSITIONS									
	2	3	4	5	6	7	8	9	10	
A	58	76	94	112	130	148	166	184	202	
B	18	18	18	18	18	18	18	18	18	
C	20	20	20	20	20	20	20	20	20	
D	20	20	20	20	20	20	20	20	20	
Weight gr.	55	80	105	130	155	180	205	230	255	

Weight "see table"

Gang mounting manifold for valves and solenoid valves G 1/8"

Ordering code

6.10.18.25/N

* N. OF POSITIONS

- 2 = N. 2 positions
- 3 = N. 3 positions
- 4 = N. 4 positions
- 5 = N. 5 positions
- 6 = N. 6 positions
- 7 = N. 7 positions
- 8 = N. 8 positions
- 9 = N. 9 positions
- 10 = N. 10 positions

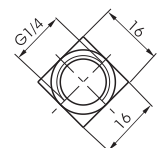
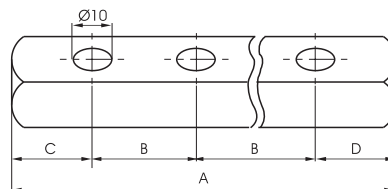

	* N. OF POSITIONS									
	2	3	4	5	6	7	8	9	10	
A	70	95	120	145	170	195	220	245	270	
B	25	25	25	25	25	25	25	25	25	
C	20	20	20	20	20	20	20	20	20	
D	25	25	25	25	25	25	25	25	25	
Weight gr.	80	115	150	185	220	255	290	325	360	

Weight "see table"

Gang mounting manifold for valves and solenoid valves G 1/8"

Ordering code
6.10.18.26/N
* N. OF POSITIONS
2 = N. 2 positions
3 = N. 3 positions
4 = N. 4 positions
5 = N. 5 positions
N 6 = N. 6 positions
7 = N. 7 positions
8 = N. 8 positions
9 = N. 9 positions
10 = N. 10 positions

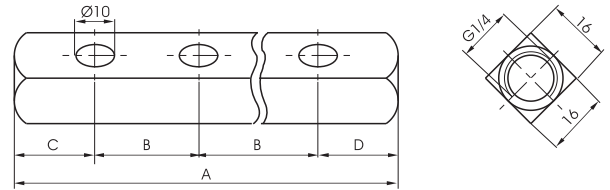

	* N. OF POSITIONS									
	2	3	4	5	6	7	8	9	10	
A	66	92	118	144	170	196	222	248	274	
B	26	26	26	26	26	26	26	26	26	
C	20	20	20	20	20	20	20	20	20	
D	20	20	20	20	20	20	20	20	20	
Weight gr.	70	110	145	185	220	260	300	340	375	

Weight "see table"

Gang mounting manifold for valves and solenoid valves G 1/8"

Ordering code
6.10.18.30/N
* N. OF POSITIONS
2 = N. 2 positions
3 = N. 3 positions
4 = N. 4 positions
N 5 = N. 5 positions
6 = N. 6 positions
7 = N. 7 positions
8 = N. 8 positions
9 = N. 9 positions
10 = N. 10 positions

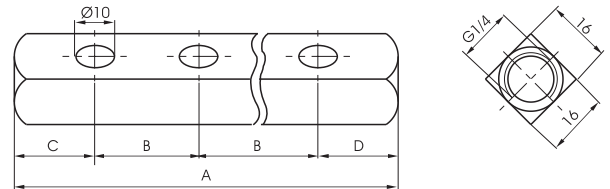

	* N. OF POSITIONS									
	2	3	4	5	6	7	8	9	10	
A	80	110	140	170	200	230	260	290	320	
B	30	30	30	30	30	30	30	30	30	
C	25	25	25	25	25	25	25	25	25	
D	25	25	25	25	25	25	25	25	25	
Weight gr.	100	140	180	220	260	300	340	380	420	

Weight "see table"

Gang mounting manifold for valves and solenoid valves G 1/8"

Ordering code
6.10.18.32/N
* N. OF POSITIONS
2 = N. 2 positions
3 = N. 3 positions
4 = N. 4 positions
5 = N. 5 positions
N 6 = N. 6 positions
7 = N. 7 positions
8 = N. 8 positions
9 = N. 9 positions
10 = N. 10 positions

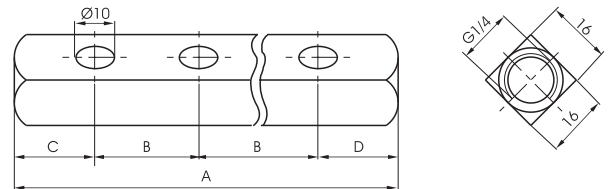

	* N. OF POSITIONS									
	2	3	4	5	6	7	8	9	10	
A	82	114	146	178	210	242	274	306	338	
B	32	32	32	32	32	32	32	32	32	
C	25	25	25	25	25	25	25	25	25	
D	25	25	25	25	25	25	25	25	25	
Weight gr.	100	145	190	235	280	325	370	415	460	

Weight "see table"

Gang mounting manifold for valves and solenoid valves G 1/8"

Ordering code

6.10.18.35/N

* N. OF POSITIONS

- 2 = N. 2 positions
- 3 = N. 3 positions
- 4 = N. 4 positions
- 5 = N. 5 positions
- 6 = N. 6 positions
- 7 = N. 7 positions
- 8 = N. 8 positions
- 9 = N. 9 positions
- 10 = N. 10 positions

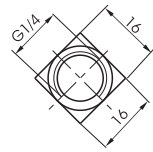
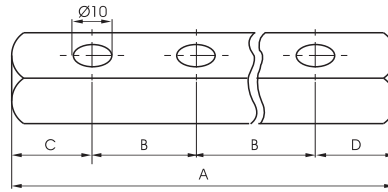

* N. OF POSITIONS

	2	3	4	5	6	7	8	9	10
A	89	124	159	194	229	264	299	334	369
B	35	35	35	35	35	35	35	35	35
C	27	27	27	27	27	27	27	27	27
D	27	27	27	27	27	27	27	27	27
Weight gr.	110	160	210	260	310	360	410	460	510

Weight "see table"

Gang mounting manifold for valves and solenoid valves G 1/4"

Ordering code

6.10.14.20/N

* N. OF POSITIONS

- 2 = N. 2 positions
- 3 = N. 3 positions
- 4 = N. 4 positions
- 5 = N. 5 positions
- 6 = N. 6 positions
- 7 = N. 7 positions
- 8 = N. 8 positions
- 9 = N. 9 positions
- 10 = N. 10 positions

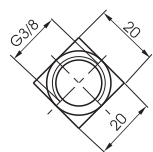
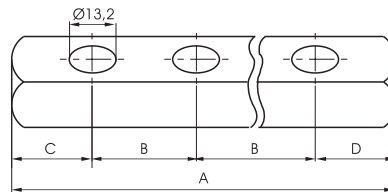

* N. OF POSITIONS

	2	3	4	5	6	7	8	9	10
A	65	85	105	125	145	165	185	205	225
B	20	20	20	20	20	20	20	20	20
C	22,5	22,5	22,5	22,5	22,5	22,5	22,5	22,5	22,5
D	22,5	22,5	22,5	22,5	22,5	22,5	22,5	22,5	22,5
Weight gr.	130	150	190	190	210	230	250	270	290

Weight "see table"

Gang mounting manifold for valves and solenoid valves G 1/4"

Ordering code

6.10.14.25/N

* N. OF POSITIONS

- 2 = N. 2 positions
- 3 = N. 3 positions
- 4 = N. 4 positions
- 5 = N. 5 positions
- 6 = N. 6 positions
- 7 = N. 7 positions
- 8 = N. 8 positions
- 9 = N. 9 positions
- 10 = N. 10 positions

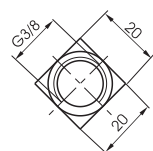
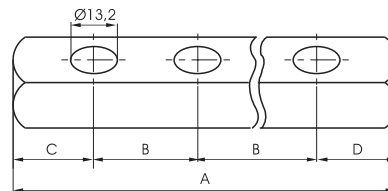

* N. OF POSITIONS

	2	3	4	5	6	7	8	9	10
A	75	100	125	150	175	200	225	250	275
B	25	25	25	25	25	25	25	25	25
C	25	25	25	25	25	25	25	25	25
D	25	25	25	25	25	25	25	25	25
Weight gr.	140	170	200	230	260	290	320	350	380

Weight "see table"

Gang mounting manifold for valves and solenoid valves G 1/4"

Ordering code
6.10.14.30/N
* N. OF POSITIONS
2 = N. 2 positions
3 = N. 3 positions
4 = N. 4 positions
5 = N. 5 positions
N 6 = N. 6 positions
7 = N. 7 positions
8 = N. 8 positions
9 = N. 9 positions
10 = N. 10 positions

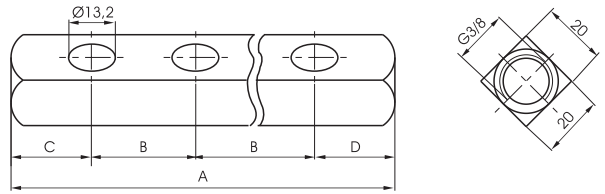

	* N. OF POSITIONS									
	2	3	4	5	6	7	8	9	10	
A	80	110	140	170	200	230	260	290	320	
B	30	30	30	30	30	30	30	30	30	
C	25	25	25	25	25	25	25	25	25	
D	25	25	25	25	25	25	25	25	25	
Weight gr.	150	190	230	270	310	350	390	430	470	

Weight "see table"

Gang mounting manifold for valves and solenoid valves G 1/4"

Ordering code
6.10.14.35/N
* N. OF POSITIONS
2 = N. 2 positions
3 = N. 3 positions
4 = N. 4 positions
N 5 = N. 5 positions
6 = N. 6 positions
7 = N. 7 positions
8 = N. 8 positions
9 = N. 9 positions
10 = N. 10 positions

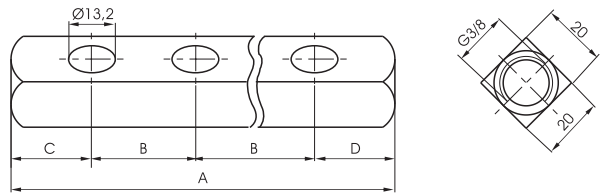

	* N. OF POSITIONS									
	2	3	4	5	6	7	8	9	10	
A	85	120	155	190	225	260	295	335	365	
B	35	35	35	35	35	35	35	35	35	
C	30	30	30	30	30	30	30	30	30	
D	20	20	20	20	20	20	20	20	20	
Weight gr.	160	210	260	310	360	410	460	510	560	

Weight "see table"

Gang mounting manifold for valves and solenoid valves G 1/4"

Ordering code
6.10.14.45/N
* N. OF POSITIONS
2 = N. 2 positions
3 = N. 3 positions
4 = N. 4 positions
5 = N. 5 positions
N 6 = N. 6 positions
7 = N. 7 positions
8 = N. 8 positions
9 = N. 9 positions
10 = N. 10 positions

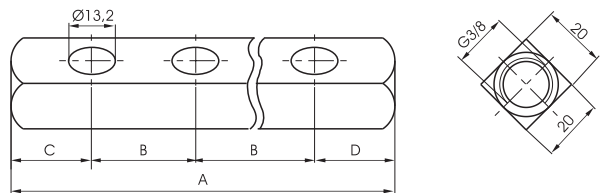

	* N. OF POSITIONS									
	2	3	4	5	6	7	8	9	10	
A	115	160	205	250	295	340	385	430	475	
B	45	45	45	45	45	45	45	45	45	
C	35	35	35	35	35	35	35	35	35	
D	35	35	35	35	35	35	35	35	35	
Weight gr.	200	275	350	425	500	575	650	725	800	

Weight "see table"

Spry valves

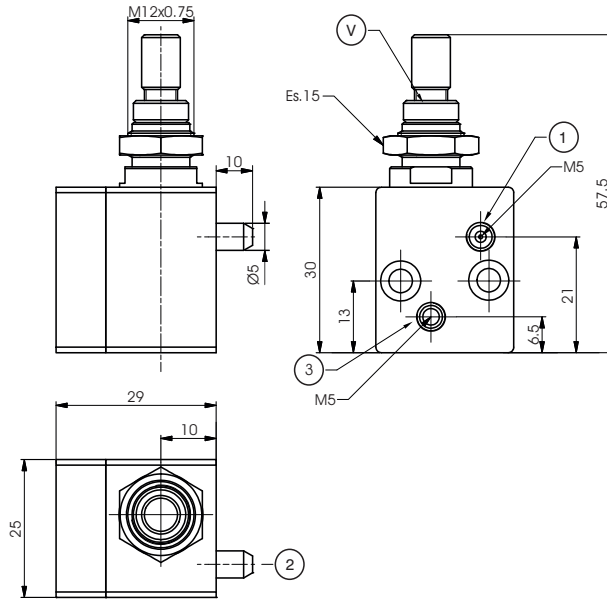

Ordering code

6.13.00

Supply air : Connection 1
Output (air and nebulized liquid) : Connection 2
Supply liquid : Connection 3

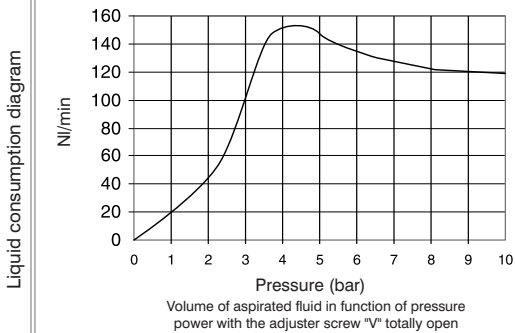

Pneumatics symbol

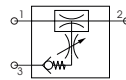

Vacuum diagram

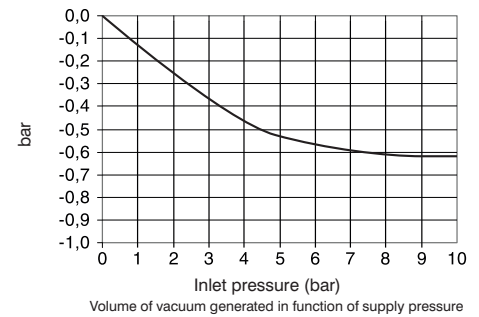

Operational characteristic

- This valve, is based on the Venturi principle, and it is used to spray and nebulize a liquid.
- Useful in all applications where is needed a continuous lubrication and / or refrigeration.
- Incoming air (connection 1) sucks the liquid through the venturi principle (connection 3) to obtain a continuous spray output (connection 2).

Technical characteristic

Fluid	Filtered and lubricated air
Liquid	Water and oil (Liquid viscosity 3°E-5°E)
Working pressure	3 - 10 bar
Operating temperature	-5°C - +70°C
Weight	85gr.